



# REEFER™ Skimmer

User Manual



# REEFER™ Skimmer

Efficient - Quiet - Ergonomic

---

User Manual



## Contents

Features of the REEFER™ Skimmers.....	7
Safety Instructions.....	8
Parts Diagram.....	9
Assembly.....	10
Installation.....	13
Operation.....	13
Maintenance.....	14
Troubleshooting.....	15
Warranty.....	16

## Welcome

Congratulations on the purchase of your Red Sea REEFER™ Skimmer.

The REEFER™ Skimmer combine high performance with innovative design features, super quiet operation and ease of use.

To get the maximum benefit from your new skimmer follow the instructions and recommendations contained in this manual.

If you have any difficulties installing or operating this product please contact our after sales service team through our web-site.

Wishing you successful reefing,  
Red Sea Team.

## Introduction to protein skimming

Protein skimming (also called foam fractionation) can be considered as a form of fine mechanical filtration since it is a physical process of removing substances from the water. Whilst a mechanical filter removes large particles such as uneaten fish food, a protein skimmer removes suspended or dissolved organic waste and invisible particles from the aquarium water.

The advantage of protein skimming lies in the fact that waste material is continuously removed, separating it from the water flow. The waste, suspended in foam, is then collected into a cup where it is no longer in contact with the aquarium water. In contrast, the dirt collected in an ordinary mechanical filter stays in contact with the water flow. A mechanical filter should therefore be cleaned very regularly; otherwise bacteria will decompose the collected dirt into harmful dissolved organic material.

A successful reef aquarium should have both a regularly cleaned mechanical filter and an efficient protein skimmer as the first and second stage of the water treatment process.

### Why is protein skimming important?

Protein skimming plays a very important role in reducing the amount of dissolved organic material in your aquarium water. This material consists of protein, carbohydrate and fat fragments together with other waste produced by the living organisms in the aquarium.

Since these could break down to potentially harmful materials to the aquarium inhabitants, rapid removal is essential.

Efficient removal of dissolved waste also helps to:

- Limit the build-up of harmful organic compounds including dissolved organic carbon, nitrogenous components (ammonia, nitrite, nitrate)

and phosphates.

- Reduce the quantity of harmful floating bacteria, since bacteria need dissolved organic material in order to grow and reproduce.
- Increase ORP (Oxidation, Reduction potential also known as REDOX) and dissolved oxygen levels.
- Prevent the development of slime algae (Cyanobacteria or blue green algae). The main food source of these primitive algae (dissolved organic material, nitrate and phosphate) is kept at a very low concentration.

### REEFER™ Skimmer Ratings

The REEFER™ Skimmers are rated according to Red Sea's REEF-SPEC® criteria that includes a water throughput, water to air ratio and contact time necessary to efficiently strip pollutants from the water. Powered by the Sicce PSK pumps, the stated air and water flow rates are actual measurements of these pumps when running on the REEFER™ Skimmers.

Model	RSK-300	RSK-600	RSK-900
SPS rating (L/Gal)	300 / 80	600 / 160	900 / 240
Mixed Reef rating (L/Gal)	600 / 160	1200 / 320	1800 / 500
Fish Only rating (L/Gal)	900 / 240	1800 / 500	2700 / 740
Pump (Sicce)	PSK-600	PSK-1000	PSK-1200
Air flow (lph/gph)	500 / 130	750 / 195	900 / 235
Water flow (lph/gph)	1000 / 265	1500 / 400	2000 / 530
Total Height (cm/inch)	53cm / 21"	56cm / 22"	59cm / 23"
Recommended Water Height	16-20cm 6-8"	18-20cm 7-8"	20-24cm 8-9"

## Features of the REEFER™ Skimmers

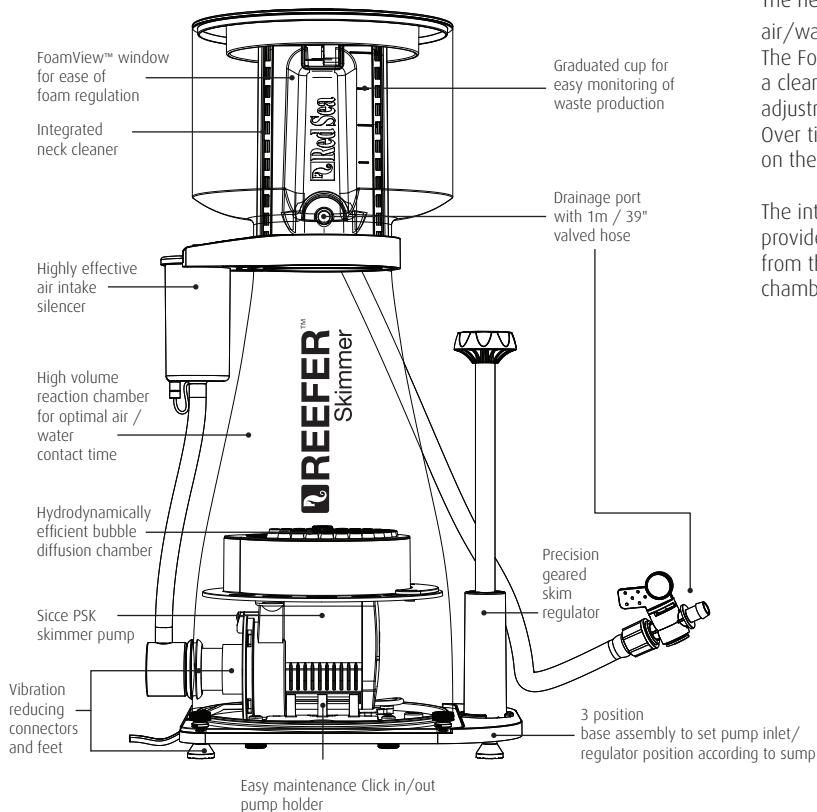

## Unique Features

The neck of the protein skimmer is the section where the dense bubbling air/water mixture gradually transforms into a stable foam.

The FoamView™ window built into the front of the collection cup provides a clear view of the foam formation inside the skimmer neck, enabling easy adjustment to reach the desired consistency of the foam.

Over time, if not cleaned regularly, a thick layer of organic sludge will form on the inside of the neck, reducing foam production by 30-40%.

The integrated manual neck cleaning system of the REEFER™ Skimmer provides a simple and effective solution by scraping the organic deposits from the neck. Any of the organics that fall back into the top of the reaction chamber are immediately flushed back up into the collection cup.

### Important Safety Instructions

## PLEASE READ AND FOLLOW ALL SAFETY INSTRUCTIONS

**DANGER:** To avoid possible electric shock, special care should be taken when handling a wet aquarium. For each of the following situations, do not attempt repairs yourself; return the appliance to an authorized service facility for service or discard the appliance.

**WARNING:** To guard against injury, basic safety precautions should be observed, including the following:

- a. Do not operate any appliance if it has a damaged cord or plug, if it is malfunctioning, or if it is dropped or damaged in any manner.
- b. To avoid the possibility of the appliance, plug or receptacle getting wet, position the Skimmer to one side of a wall mounted receptacle to prevent water from dripping onto the receptacle or plug. A "drip loop", as shown in the diagram should be arranged for each cord connecting an aquarium appliance to a receptacle. The drip loop is that part of the cord below the level of the receptacle or the connector. Use an extension cord if necessary to prevent water traveling along the cord and coming into contact with the receptacle.
- c. If the plug or receptacle does get wet, DO NOT un-plug the cord. Disconnect the fuse or circuit breaker that supplies power to the appliance. Then, unplug the device and examine for presence of water in the receptacle.
- d. Close supervision is necessary when any appliance is used by or near children.
- e. To avoid injury, do not contact moving parts.
- f. Always unplug an appliance from an outlet when not in use, before

putting on or taking off parts, and before cleaning. Never pull the cord itself to remove the plug from the outlet. Grasp the plug firmly and pull to disconnect.

- g. Do not use an appliance for anything other than its intended use. The use of attachments not recommended or sold by the appliance manufacturer may cause an unsafe condition.
- h. Do not install or store the appliance where it will be exposed to the weather or to temperatures below freezing point.
- i. Make sure an appliance mounted on a tank is securely installed before operating it.
- j. Read and observe all IMPORTANT notices on the appliance.
- k. If an extension cord is necessary, a cord with a proper rating should be used.

### SAVE THESE INSTRUCTIONS

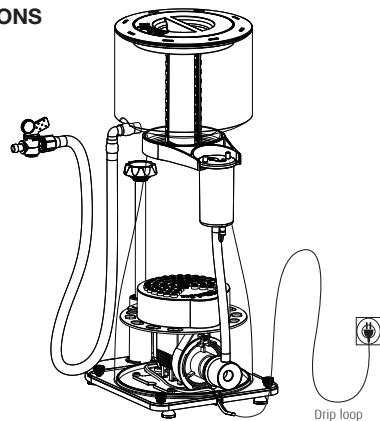

## REEFER™ Skimmer Parts Diagram

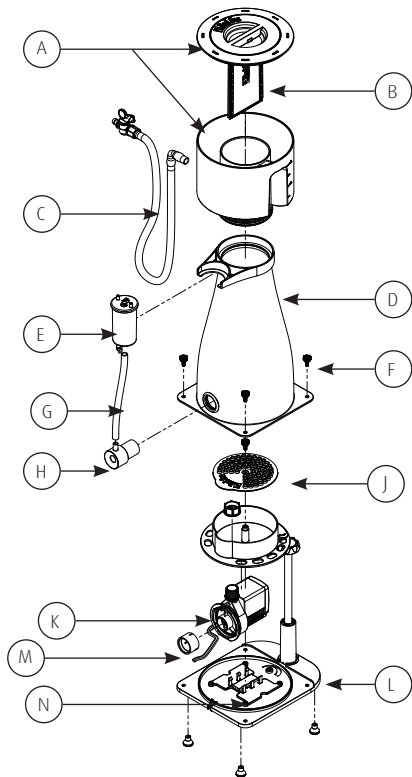

Part Identification	Part Description	REEFER™ Skimmer 300 R50503	REEFER™ Skimmer 600 R50506	REEFER™ Skimmer 900 R50509	Qty.
A	Collection Cup & Lid	R50523	R50533	R50543	1
B	Wiper & Blades	R50527	R50537	R50547	1
C	Waste Tube & Valve	R50564	R50564	R50564	1
D	Body	R50524	R50534	R50544	1
E	Silencer	R50560	R50560	R50560	1
F	Screw Pack	R50567	R50567	R50567	9
G	Venturi Tube	R50563	R50563	R50563	1
H	Venturi	R50528	R50538	R50548	1
J	Diffuser	R50526	R50536	R50546	1
K	Pump	R50520	R50530	R50540	1
L	Base	R50525	R50535	R50545	1
M	Rubber Pack	R50566	R50566	R50566	1
N	Pump Holder	R50561	R50561	R50561	1



## Assembly

Remove the components from the protective packaging and familiarize yourself with them.

Note: The skimmer body has been assembled in a unique position for transportation purposes only.

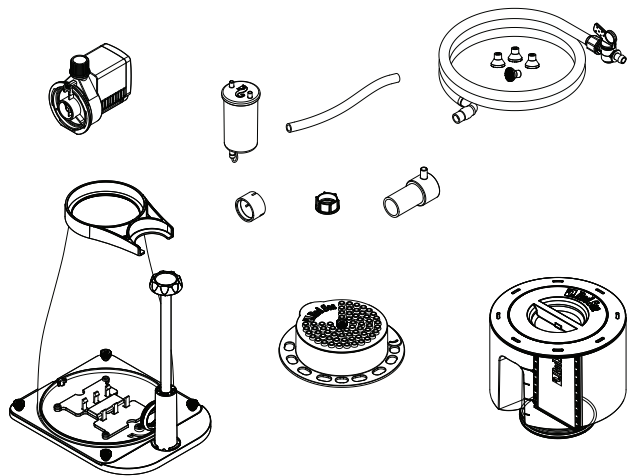

### Placement & Orientation:

The REEFER™ Skimmers are designed to allow 3 distinct orientations of the venturi pump inlet relative to the Skim regulator (left/center/right) enabling the skimmer to be customized for the specific layout of your sump. There must be at least 2.5cm (1") of unobstructed water column in front of the venturi inlet. There must be at least 2.5cm (1") of free space above the collection cup to allow it to be removed for cleaning.

The collection cup can be freely rotated so that the FoamView™ window can be set to whatever angle is best for you when regulating the skimmer.

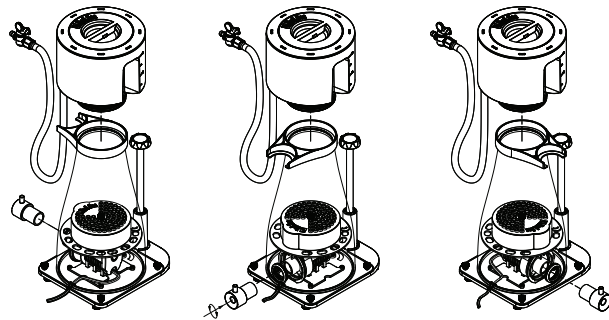

Unscrew the skimmer body from the base and if necessary reposition the pump holder to suit the desired orientation of the pump inlet. Turn the skimmer base upside-down and push the rubber feet firmly into position.

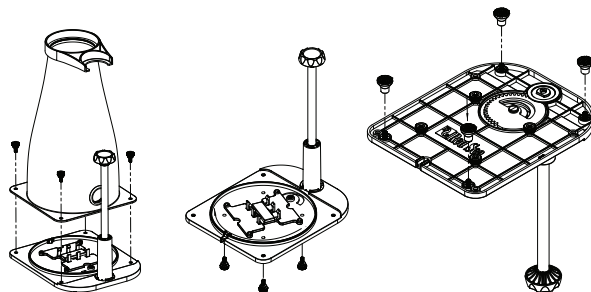

Skimmer Regulator - Rotating the regulator in the “Minus” direction will increase the opening in the base, lowering the foaming point or to produce a drier foam. Rotating in the “Plus” direction decreases the opening in the base, raising the foaming point or to produce a wetter foam.

Skimmer pumps need to be cleaned on a regular basis to remove calcium and other deposits and therefore it is recommended to familiarize yourself with the pump by disassembling/reassembling it before assembling it for the first time in the skimmer. Before pushing the pump into the pump holder make sure that the rubber damper pad is in position.

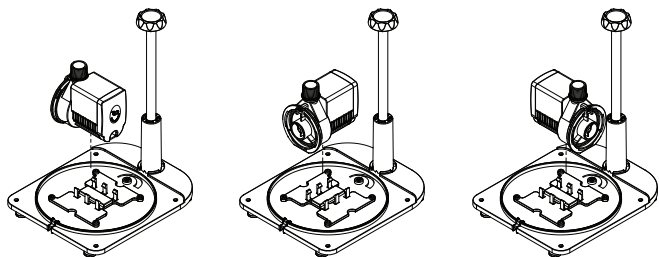

Remove the cable restraint from the base.

Run the pump cable around the pump and insert it through the cable channel and under the base.

Push the cable restraint back into position.

Note: Not using the cable restraint may affect the regulation of the skimmer

Disassemble the bubble diffusion chamber and temporarily position it above the pump. If necessary reposition the return-flow plug so that it is above the regulated outlet in the base (it is easier to do this before the diffuser is attached to

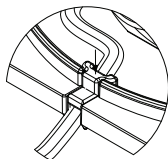

the pump). Secure the diffuser to the pump with the nut provided and attach the diffuser plate with the center screw. Make sure that diffuser is concentric with the base. Push the rubber connector onto the pump inlet.

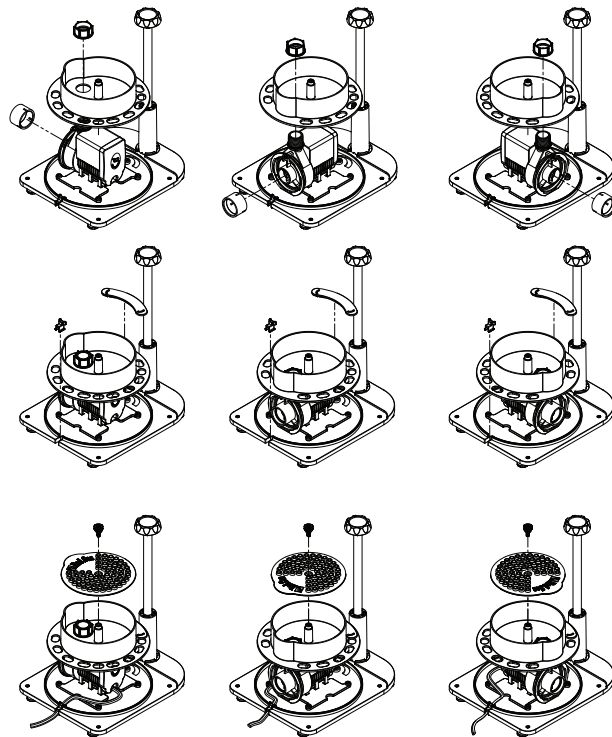

With all of the internal components assembled, lower the skimmer body onto the base so that the hole on the side is aligned with the pump inlet. Secure the body in position tightly with the 4 screws provided.

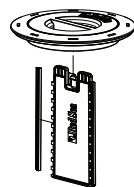
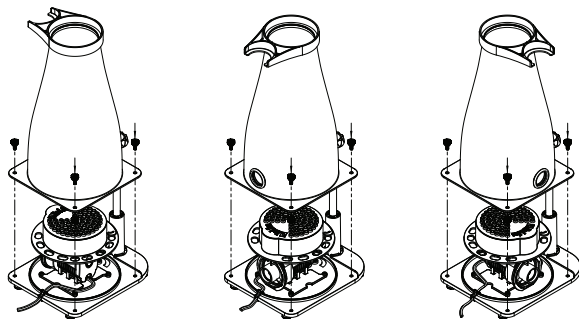

The wiper is held in the lid by snap connectors on both sides of the handle and can be removed for cleaning. Should it become necessary the wiper blades can also be removed for more thorough cleaning and/or replacement.

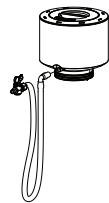

The REEFER™ Skimmers are provided with an extra-long drainage tube with an elbow connector and a watertight valve. Push the rubber tube onto the drainage outlet at the bottom of the collection cup and set the angle of the elbow to give a convenient path for the drainage tube to the front of your sump for easy periodic collection of the accumulated waste.

## Manual Neck Cleaner

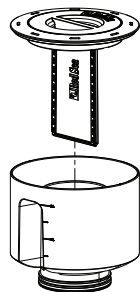

Familiarize yourself with the operation and assembly/disassembly of the manual neck cleaner.

To operate the cleaner, use the handle recess in the lid to rotate it either in the clockwise or anti-clockwise direction. This may be slightly stiff when dry however it will rotate easily when in regular use.

The lid/wiper can be removed as a single unit by pulling it up and out of the foaming section of the neck. Due to the conical shape of the foaming section a small force may be required to reinsert the wiper/lid to the cup.

Ensure that the O-ring is in position and assemble the collection cup by pushing it down into the neck of the skimmer body. This will be easier if the O-ring is wet.

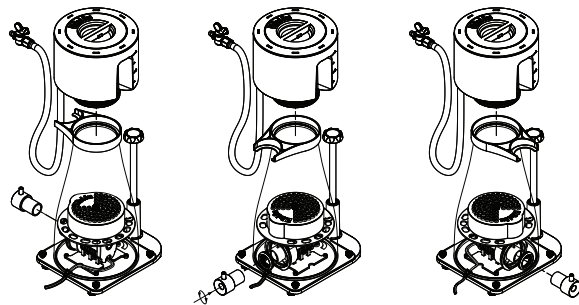

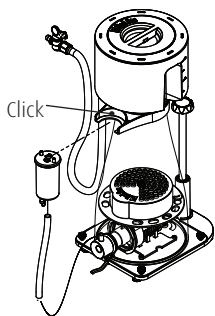

Assemble the venturi by simultaneously pushing and rotating it through the rubber grommet in the wall of the skimmer body and into the rubber connector that you previously put onto the pump inlet. When fully inserted ensure that the venturi air inlet is facing up. (This will be easier if you wet the external surface of the venturi with water – do not use any type of grease.)

Attach the air tube to the inlet of the silencer making sure that the loop of the silencer drainage port plug is in place. Also check that the drainage port plug is properly inserted in the drainage port. Click the silencer into its holder on the skimmer neck and attach the free end of the air tube to the venturi air inlet.

- Make sure that you prevent the power plug of the pump from getting wet during initial placement or future maintenance of the skimmer in the sump.
- Check that there is at least 2.5cm (1/2") of unobstructed water column in front of the venturi inlet.
- Check that the water height in the skimmer compartment of your sump is correct for your model of skimmer.
- For best results the water level in your skimmer chamber should be maintained at a constant height. This is normally achieved when your sump has an Automatic-Top-Off unit installed.
- Check that there is at least 2.5cm (1") of free space above the collection cup to allow it to be removed for cleaning.
- Find a convenient place at the front of the sump to place the valve of the drainage tube.
- Rotate the collection cup so that you have a clear line of sight to the Foamview®.

## Installation:

Congratulations, your REEFER™ Skimmer is now fully assembled and ready to be placed in the sump.

- Read the following section about skimming and regulation before switching on the pump.
- Before placing the skimmer in the sump, rotate the skim regulator fully in the minus direction. This will open the water outlet in the base allowing sump water to more freely enter the skimmer body and prevent it floating due to air trapped inside. This will also prevent over-skimming on start-up.
- The rubber feet hold the bottom of the skimmer 13mm (1/2") above the bottom of the sump therefore the power cable can safely be run under the skimmer if it helps with your cable management.

## Operation of the REEFER™ Skimmer

Skimmers produce foam as the protein from the water sticks to the surface of the air bubbles giving them the structural rigidity they need to ascend the neck of the skimmer and settle in the collection cup. Since foam production is proportional to the density of organic material in the aquarium water which varies over time, the foam point in the neck will need to be adjusted to ensure an efficient removal of the proteins without an excessive amount of seawater.

The REEFER™ Skimmers have a precision geared skim regulator for a very fine control of the foam point ensuring high skimming efficiency. Rotating the regulator in the "Minus" direction lowers the foaming point in the neck to produce a drier foam. Rotating in the "Plus" direction raises the foaming

point to produce a wetter foam.

Adjust the skim regulator so that the water level in the skimmer body is approximately at the base of the neck. If the foam is too dry or it starts to accumulate lower in the neck, gradually rotate the Skim Regulator in the “Plus” direction until the desired foam consistency is achieved. Alternatively, if the foam is too wet, gradually rotate the Skim Regulator in the “Minus” direction.

**New set-ups** typically have a negligible amount of organic matter in the water and therefore it may take some time for a skimmate to be produced.

**New skimmers** sometimes need a short break-in period of a few days before they begin to function efficiently. Over-skimming (an uncontrollable flow of aerated water into the collection cup) is common while harmless chemical residues that affect the surface tension of the water are neutralized. In case of over-skimming rotate the regulator fully in the Minus direction and allow the over-skimming to naturally reduce in intensity.

### **Feeding and Supplementing**

Skimmers are very susceptible to the effect of surface-active compounds such as foods and supplements that are added regularly to the aquarium. Such materials can significantly affect the foam production and in some cases cause over-skimming. Immediately before adding such materials switch the skimmer off and leave off for 30 minutes or however long it takes until the skimmer will return to its normal foaming action without repositioning the Skim Regulator.

## **Maintenance**

### **Collection Cup**

Monitor the amount of skimmate that accumulates in the collection cup and drain the cup on a regular basis. Skimmer performance will benefit from using the neck cleaner on a daily basis and will enable you to only remove and wash the cup and wiper every 7 – 10 days. If you wash the cup with detergent make sure to rinse it thoroughly before returning it to the skimmer.

### **Skimmer Pump & Impeller**

Over time mineral and organic deposits will form inside the pump affecting its performance and longevity. For best results it is recommended to remove the pump from the skimmer once a month for cleaning. Open the pump impeller chamber, pull out the impeller and rinse all parts under the tap.

If you see any buildup of scale on the inside of the pump housing or on the impeller magnet, use hot water or vinegar/scale remover to dissolve it. Make sure that you rinse off all residues of any cleaning materials before reassembling the pump.

## Troubleshooting

**Q.** The bubbles in the skimmer are too large.

**A.** Ensure that you are using the skimmer in saltwater at the correct specific gravity. Freshwater cannot be efficiently skimmed using a protein skimmer.

**Q.** My skimmer is new (or just cleaned) and doesn't seem to be skimming.

**A.** If your skimmer is new, clean it with fresh water and rinse thoroughly with hot water. Allow the skimmer to run for 48 hours to remove any harmless residues from the production process. These materials are safe for your aquarium, but impede the skimmer's ability to foam efficiently for a couple of days.

**Q.** My aquarium is full of micro bubbles or air mist.

**A.** All skimmers release some air bubbles to the sump and therefore it is best to have a bubble trap between the skimmer chamber and the return pump. If your skimmer is new allow a few days for the skimmer to settle in.

**Tip:** You might be getting micro bubbles if you are using tap water with water conditioners or natural seawater. Many conditioners/impurities found in natural seawater increase the surface tension of the water and cause a small proportion of the bubbles to escape the skimmer chamber.

**Q.** My skimmer is producing a lot of weak, watery foam.

**A.** Rotating the regulator in the "Minus" direction lowers the foaming point in the neck to produce a drier foam.

**Tip:** Production of an excessive amount of weak, watery foam is also referred to as over-skimming. This often indicates the presence of chemical substances that need to be removed by the skimmer. Many water conditioners/impurities found in natural seawater increase the surface tension of the water and cause serious over-skimming.

**Tip:** If you are using natural seawater, you should be aware that most seawater today contains traces of pollutants, e.g. phenols, carbohydrates, oils, etc.

Therefore, natural seawater is not recommended for use in reef aquaria. We strongly recommend NOT using tap water. If you intend to use it, however, DO NOT add conditioners/de-chlorinators. Instead, allow the water to settle for 24 hours for the chlorine to evaporate naturally before introducing it to the aquarium.

**Tip:** Some brands of synthetic salt contain binding substances, such as EDTA, that increases surface tension and causes over-skimming.

**Q.** There is a reduction in the quantity of air bubbles in my skimmer.

**A.** Check for blockages in the silencer, air tube or venturi. If the problem persists, clean the skimmer pump.

**Q.** I cannot regulate my skimmer.

**A.** Check that the water level in skimmer chamber of your sump is as recommended. Try raising or lowering the water level by approximately 12mm (1/2"). Check that the water outlet on the bottom of the skimmer has not become blocked. Clean the skimmer pump.

**Q.** The aspiration pump is making a rattling noise.

**A.** Clean the skimmer pump and check for damage to the impellor.

**Q.** The skimmer is making a gurgling noise.

**A.** There may be water trapped in the silencer. Remove the drain plug and let out any accumulated water. Remember to return the plug.

## Warranty

### Red Sea Fish Pharm Aquarium Products Limited Warranty

The limited warranty sets forth all Red Sea Fish Pharm Ltd (Red Sea) responsibilities regarding this product. There are no other express or implied warranties from Red Sea. Red Sea warrants your product against defects in materials and workmanship for a period of 12 months, valid from the date of original purchase and will repair this product free of charge (not including shipping costs) with new/rebuilt parts. The precondition for the warranty is that the stipulated set- up routine is observed. In the event that a problem develops with this product during or after the warranty period, contact your local dealer or Red Sea (at the company address indicated) for details of your nearest authorized service center.

The warranty is extended only to the original purchaser. Proof of date of purchase will be required before warranty performance is rendered. This warranty only covers failures due to defects in materials or workmanship which occur during normal use. It does not cover damage which occurs in shipment or failures which result from misuse, abuse, neglect, improper installation, operation, mishandling, misapplication, alteration, modification or service by anyone other than an authorized Red Sea service center. Red Sea shall not be liable for incidental or consequential damages resulting from the use of this product, or arising out of any breach of this warranty. All express and implied warranties, including the warranties of salability and fitness for particular purpose, are limited to the applicable warranty period set forth above. These statements do not affect the statutory rights of the consumer. USA Some states do not allow the exclusion or limitation of incidental or consequential damages, or limitations on how long an implied warranty lasts, so the above exclusion or limitations may not apply.

### **Red Sea U.S.A**

4687 World Houston  
Parkway #150 Houston,  
TX 77032, U.S.A  
support.usa@redseafish.com

### **Red Sea Europe**

655 Rue des Frères  
Lumière 27130 Verneuil  
d'Avre et d'Iton, France  
Tel: (33) 2 32 37 71 37  
support.fr@redseafish.com

### **UK & Ireland**

**Red Sea Aquatics (UK) Ltd**  
PO Box 1237  
Cheddar, BS279AG  
uk.info@redseafish.com

### **Germany & Austria**

**Red Sea Deutschland**  
Büro Deutschland  
Prinzenallee 7 (Prinzenpark)  
40549 Düsseldorf  
support.de@redseafish.com

### **China**

**Red Sea Aquatics (GZ) Ltd**  
Block A3, No 33 Hongmian Road,  
Xinhua Industrial Park, Huadu  
District, Guangzhou City, China,  
Postal code 510800.  
Tel: +86-020-6625 3828  
info.china@redseafish.com

株式会社エムエムシー企画  
レッドシー事業部  
〒174-0063  
東京都板橋区前野町6-29-4  
info@mmclanning.com

